

Acuvim II

Advanced Power & Energy
Meter Datasheet

ACCUENERGY



DESCRIPTION

The Acuvim II Series advanced power and energy meters are the simple, robust solution for power monitoring, kWh metering, power quality analysis, and more. This multifunction meter is engineered for easy integration into any project environment and a wide array of plug-in expansion modules facilitate communication on over 15 different industry-standard protocols. Its two, available form factors include a Panel Mount meter with a digital display or a DIN Rail Transducer configuration.

FEATURES

- + Revenue grade: ANSI C12.20 class 0.2 & IEC 62053-22 class 0.2s
- + Data Logging available in 8MB, 16MB, 4GB, and 8GB with WEB2 module
- + Modbus-RTU & BACnet MS/TP ready. Optional modules add support for multiple industrial protocols & interfaces such as Modbus-TCP/IP, BACnet-IP, IEC 61850, EtherNet/IP and WiFi
- + Available compatibility with multiple CT output options including 5A, mA, RCT (Rogowski), or 333mV
- + Designed with industry-leading cybersecurity
- + Configure as a panel mount meter with digital display or DIN rail mount transducer

KEY FEATURES

Communication

- + Modbus RTU Protocol and BACnet MS/TP via RS485
- + Ethernet (Modbus TCP, HTTP, SMTP, SNTP, HTTPs Post, FTP)
- + PROFIBUS DP
- + BACnet IP, BACnet MS/TP
- + Dual RS485 Communication Ports
- + Wi-Fi and Ethernet Communication Channels (Modbus TCP, HTTP, SMTP, SNTP, HTTPs Post, FTP)
- + Mesh Wireless Module 868Hz or 900Hz

Data Logging

- + Acuvim IIR/IIE/IIW meters offer three, assignable historical logs and a real time clock to record many metering parameters with accurate timestamping. Add the AXM-WEB2 module to expand the memory to 8GB with an adjustable log size.

Fast Response

- + 512 samples per cycle, rapid logging options available with 100ms and 50ms refresh rate available with WEB2 expansion module.

Time of Use

- + Users can assign up to four tariffs (sharp, peak, valley, & normal) to different time periods within a day. The Acuvim IIE meter will calculate and accumulate energy to different tariffs according to the meter's internal clock and TOU settings.

Display

- + Clear, large character LCD with white backlight
- + Wide environmental temperature endurance
- + View load percentage, 4 quadrant powers, & load nature

Optional I/O Module

- + Expand Acuvim II I/O functionality by connecting an optional I/O module. A maximum of three modules can be used per meter. Digital input, digital output, pulse output, relay output, analogue input, and analogue output I/O modules are available.

Alarms

- + Limits can be set for up to 16 indicated parameters with a specified time interval. Parameters that are over or under setting limit and persist longer than the specified time interval will be recorded and trigger the Alarm DO. Choose from 80 available parameters.

Power Quality Event Logging

- + The Acuvim IIW can record the triggering condition of power quality events, such as voltage sags or swells, with a timestamp. Up to 50,000 PQ events can be saved.

Waveform Capture

- + With a settable triggering condition, the Acuvim IIW can record 100 groups of voltage and current waveforms plus the waveform 10 cycles before and after the triggering point. Connect the AXM-WEB2 module to save waveform files in COMTRADE format.

Automatic Frequency Adaptation

- + Rated frequency automatically adjusts to local frequencies, such as 50Hz or 60Hz, making it ideal in countries with differing electrical frequencies.

Flexible Current Transformer Options

- + The Acuvim II is directly compatible with Rogowski coils plus a variety of other current transformer outputs including 5A, 1A, 80mA, 100mA, 200mA, and 333mV. All CTs are available from Accuenergy.



APPLICATIONS

- + Submetering
- + Measurement & Verification
- + Energy Storage & MicroGrids
- + Building Automation
- + Energy Management Systems
- + Energy Generation and Distribution

SPECIFICATIONS

Metering

PARAMETERS		ACCURACY	RESOLUTION	RANGE
Voltage		0.2%	0.1V	10V~1000kV
Current		0.2%	0.1mA	5mA~50000A
Power		0.2%	1W	-9999MW~9999MW
Reactive Power		0.2%	1var	-9999Mvar~9999Mvar
Apparent Power		0.2%	1VA	0~9999MVA
Power Demand		0.2%	1W	-9999MW~9999MW
Reactive Power Demand		0.2%	1var	-9999Mvar~9999Mvar
Apparent Power Demand		0.2%	1VA	0~9999MVA
Power Factor		0.2%	0.001	-1.000~1.000
Frequency		0.02%	0.001Hz	45.00~65.00Hz (50 or 60Hz type) 300.00Hz~500.00Hz (400Hz type)
Energy	Primary	0.2%	0.1kWh	0-99999999.9kWh
	Secondary	0.2%	0.001kWh	0-999999.999kWh
Reactive Energy	Primary	0.2%	0.1kvarh	0-99999999.9kvarh
	Secondary	0.2%	0.001kvarh	0-999999.999kvarh
Apparent Energy	Primary	0.2%	0.1kVAh	0-99999999.9kVAh
	Secondary	0.2%	0.001kVAh	0-999999.999kVAh
Harmonics		1.0%	0.1%	
Phase Angle		2.0%	0.1°	0.0°~359.9°
Unbalance Factor		2.0%	0.1%	0.0%~100.0%
Running Time			0.01h	0~9999999.99h

Input

CURRENT INPUTS (EACH CHANNEL)

Nominal Current Options	① 5A, ② 1A, ③ 1A (333mV) ④ 1A (100mV Rope CT) ⑤ 1A (80mA/100mA/200mA)
Metering Range	① 0-10A, ② 0-2A, ③ 0-1.2A, ④ 0-1.2A, ⑤ 0-1.2A
Pickup Current	① 5mA, ② 1mA, ③ 5mA, ④ 5mA, ⑤ 5mA
Withstand	20Arms Continuous, 0.1% of Nominal 100Arms for 1 second, Non-Recurring
Burden	0.05VA (Typical) @ 5A RMS
Accuracy	0.2% Full Scale

VOLTAGE INPUTS (EACH CHANNEL)

Nominal Full Scale	400Vac L-N, 690Vac L-L (+20%)
Withstand	1500Vac Continuous 2500Vac, 50/60Hz for 1 Minute
Input Impedance	2MΩ per Phase
Metering Frequency	45Hz~65Hz, 300Hz~500Hz
Pickup Voltage	10Vac
Accuracy	0.2% Full Scale

ENERGY ACCURACY

Active	Class 0.2s (According to IEC 62053-22) Class 0.2 (According to ANSI C12.20)
Reactive	Class 2 (According to IEC 62053-23)

HARMONIC RESOLUTION

Metered Value	63rd Harmonic (50Hz or 60Hz type) 15th Harmonic (400Hz type)
---------------	---

Communications

Modbus-RTU or BACnet MS/TP	Modbus-RTU 2-Wire Shielded Twisted Pair Cable Connection 1200~115200 bps
SECOND RS-485 PORT (OPTIONAL MODULE)	Same as the primary RS485 port Baud Rate: 4800~38400 bps
ETHERNET (OPTIONAL MODULE)	Ethernet 10M/100M BaseT MODBUS-TCP/IP DNP 3.0 Over IP Level 2 IEC 61850 2nd Edition SNMP V3 BACnet-IP HTTP/HTTps Webserver HTTP/HTTps, FTP data post SMTP MQTT MV90 NTP
PROFIBUS (OPTIONAL MODULE)	PROFIBUS-DP/V0 Protocol Work as PROFIBUS Slave, Baud Rate Adaptive, up to 12M Model 1: Input Bytes: 32, Output Bytes: 32 Model 2: Input Bytes: 64, Output Bytes: 2 PROFIBUS Standard According to EN 50170 Vol. 2

SPECIFICATIONS

I/O Options

DIGITAL INPUT

Input Type	Dry
Input Resistance	100kΩ
Input Voltage Range	20~160 Vac/dc
Input Current (Max)	2mA
Start Voltage	15V
Stop Voltage	5V
Pulse Frequency (Max)	100Hz, 50% Duty Ratio (5ms ON and 5ms OFF)
SOE Resolution	2ms

DIGITAL OUTPUT (DO) (PHOTO-MOS)

Voltage Range	0~250Vac/dc
Load Current	100mA (Max)
Output Frequency	25Hz, 50% Duty Ratio (20ms ON, 20ms OFF)
Isolation Voltage	2500Vac

RELAY OUTPUT (RO) (NO, Form A)

Switching Voltage (Max)	250Vac, 30Vdc
Load Current	5A(R), 2A(L)
Set Time	10ms (Max)
Contact Resistance	30mΩ (Max)
Isolation Voltage	2500Vac
Mechanical Life	1.5x10 ⁷

ANALOGUE OUTPUT (AO)

Output Range	0~5V, 0~20mA 1~5V, 4~20mA Optional
Accuracy	0.50%
Temperature Drift	50ppm/°C Typical
Isolation Voltage	500Vdc
Open Circuit Voltage	15V

ANALOGUE INPUT (AI)

Input Range	0~5V, 0~20mA 1~5V, 4~20mA Optional
Accuracy	0.20%
Temperature Drift	50ppm/°C Typical
Isolation Voltage	500Vdc

POWER SUPPLY FOR DI (24 VDC)

Output Voltage	24Vdc
Output Current	42mA
Load (Max)	21 DIs

Control Power

Universal	AC or DC
-----------	----------

AC/DC CONTROL POWER

Operating Range	100~415Vac, 50/60Hz; 100~300Vdc
Burden	5W
Frequency	50/60Hz
Withstand	3250Vac, 50/60Hz for 1 minute
	Installation Category III (Distribution)

LOW VOLTAGE DC CONTROL POWER (OPTIONAL)

Operating Range	20~60Vdc
Burden	5W

Operating Environment

Operating Temperature	-25°C to 70°C -13°F to 158°F
Storage Temperature	-40°C to 85°C -40°F to 176°F
Relative Humidity	5% to 95% Non-Condensing

Standard Compliance & Certifications

Measurement Standard	IEC 62053-22; ANSI C12.20
Environmental Standard	IEC 60068-2, CE, RoHS
Safety Standard	IEC 61010-1, UL 61010-1, IEC 61557-12
EMC Standard	IEC 61000-4/-2-3-4-5-6-8-11, CISPR 22, IEC 61000-3-2, IEC 61000-6-2/4
Outlines Standard	DIN 43700, ANSI C39.1
Protocol Conformance	IEC 61850 2nd Edition BTL Listed for B-SA (Acuvim II, IIR, IIE, IIW)







FUNCTION LIST

● Function; ○ Option; Blank NA



	REAL TIME METERING	Parameters	Acuvim II	Acuvim IIR	Acuvim IIE	Acuvim IIW
Metering	Phase Voltage	V1, V2, V3, Vlnavg	●	●	●	●
	Line Voltage	V12, V23, V31, Vllavg	●	●	●	●
	Current	I1, I2, I3, In, Iavg	●	●	●	●
	Power	P1, P2, P3, Psum	●	●	●	●
	Reactive Power	Q1, Q2, Q3, Qsum	●	●	●	●
	Apparent Power	S1, S2, S3, Ssum	●	●	●	●
	Power Factor	PF1, PF2, PF3, PF	●	●	●	●
	Frequency	F	●	●	●	●
	Load Features	Load Features	●	●	●	●
	Four Quadrant Powers	Four Quadrant Powers	●	●	●	●
ENERGY & DEMAND						
TOU	Energy	Ep_imp, Ep_exp, Ep_total, Ep_net, Epa_imp, Epa_exp, Epb_imp, Epb_exp, Epc_imp, Epc_exp	●	●	●	●
	Reactive Energy	Eq_imp, Eq_exp, Eq_total, Eq_net, Eq_a_imp, Eq_a_exp, Eqb_imp, Eqb_exp, Eqc_imp, Eqc_exp	●	●	●	●
	Apparent Energy	Es, Esa, Esb, Esc	●	●	●	●
	Demand	Dmd_P, Dmd_Q, Dmd_S, Dmd_I1, Dmd_I2, Dmd_I3	●	●	●	●
TIME OF USE						
TOU	Energy/max demand	TOU, 4 Tariffs, 12 Seasons, 14 Schedules			●	
	DAYLIGHT SAVINGTIME					
	Two Adjustable Formats	Month/Day/Hour/Minute, Month/Week/First few weeks/Hour/Minute			●	
WAVEFORM CAPTURE						
	Voltage and Current Waveform	Trigger, Manual, DI change, Sag/Dips, Swell, Over Current				●
POWER QUALITY						
Monitoring	Voltage Unbalance Factor	U_unbl	●	●	●	●
	Current Unbalance Factor	I_unbl	●	●	●	●
	Voltage THD	THD_V1, THD_V2, THD_V3, THD_Vavg	●	●	●	●
	Current THD	THD_I1, THD_I2, THD_I, THD_Iavg	●	●	●	●
	Individual Harmonics	Harmonics 2nd to 63rd (50H or 60Hz), Harmonics 2nd to 15th (400Hz)	●	●	●	●
	Voltage Crest Factor	Crest Factor	●	●	●	●
	TIF	THFF	●	●	●	●
	Current K factor	K Factor	●	●	●	●
STATISTICS						
	MAX with Time Stamp	Each phase of V & I; Total of P, Q, S, PF & F; Demand of I1, I2, I3, P, Q&S;	●	●	●	●
	MIN with Time Stamp	Each phase THD of V & I; Unbalance factor of V & I				
ALARM						
	Over/Under Limit Alarm	V, I, P, Q, S, PF, V_THD & I_THD Each Phase and Total or Average; Unbalance Factor of V & I; Load Type; Analogue Input of Each Channel; Demand of I1, I2, I3, P, Q&S; Reverse phase sequence; DI1~DI28	●	●	●	●
POWER QUALITY EVENT LOGGING						
	Sag/Dips, Swell	Voltage				●
DATA LOGGING						
Others	Data Logging 1	F, V1/2/3/Iavg, V12/23/13/Iavg, I1/2/3/n/avg, P1/2/3/sum, Q1/2/3/sum, S1/2/3/sum, PF1/2/3, PF, U_unbl, I_unbl, Load Type, Ep_imp, Ep_exp, Ep_total, Ep_net, Eq_imp, Eq_exp, Eq_total, Eq_net, Es, Epa_imp, Epa_exp, Epb_imp, Epb_exp, Epc_imp, Epc_exp, Eq_a_imp, Eq_a_exp, Eqb_imp, Eqb_exp, Eqc_imp, Eqc_exp, Esa, Esb, Esc, THD_V1/2/3/avg, THD_I1/2/3/avg, Harmonics 2nd to 63rd, Crest Factor, THFF, K Factor, Sequence and Phase Angles, DI Counter, AI, AO, Dmd P/Q/S, Dmd I1/2/3			●	●
	Data Logging 2				●	●
	Data Logging 3				●	●
ONBOARD MEMORY SIZE						
	Memory	Standard Meter	-	8MB	8MB	16MB
		AXM-WEB-PUSH	4GB	4GB	4GB	4GB
		AXM-WEB2	8GB	8GB	8GB	8GB
COMMUNICATION						
	RS485 Port, Half Duplex, Optical Isolated	Modbus-RTU Protocol	●	●	●	●
	Modbus-RTU and BACnet-MS/TP		●	●	●	●
TIME						
	Real Time Clock	Year, Month, Date, Hour, Minute, Second	●	●	●	●
400Hz TYPE						
	Only support full-wave energy, support 2nd~15th individual harmonics		○	○	○	

COMMUNICATION MODULE COMPARISON

● Function; ○ Option; Blank NA

	Standard	AXM WEB2 FOLC	AXM WEB2	AXM WEB PUSH	AXM PROFI	AXM RS485	AXM MESH
							
Modbus-RTU	●					●	
BACnet-MS/TP	●						
DNP 3.0 Over IP		●	●	●			
IEC 61850		●	●				
Modbus-TCP/IP		●	●	●			
HTTP/HTTPs Webserver		●	●	●			
SMTP Email		●	●	●			
SNMP V3		●	●	●			
EtherNet/IP		●	●				
MQTT		●	●				
RSTP		●	●				
IPv6		●	●				
HTTP/HTTPs Push		●	●	●			
FTP Post		●	●	●			
sFTP Server		●	●	●			
Datalogging		8GB	8GB	4GB			
BACnet-IP		●	●				
PROFIBUS					●		
WiFi		●	●				
RJ45 Ports		1	2	1			
Fiber Optics LC		●					
RF							868 MHz, 900 MHz

DIGITAL/ANALOGUE I/O

	AXM-IO1	AXM-IO2	AXM-IO3
			
Digital Input (<i>Dry</i>)	6	4	4
Digital Output	-	2	-
Relay Output	2	-	2
Analogue Inputs	-	-	2
Analogue Outputs	-	2	-
Power Supply	24Vdc	-	-

DIMENSIONS

Acuvim II Dimensions

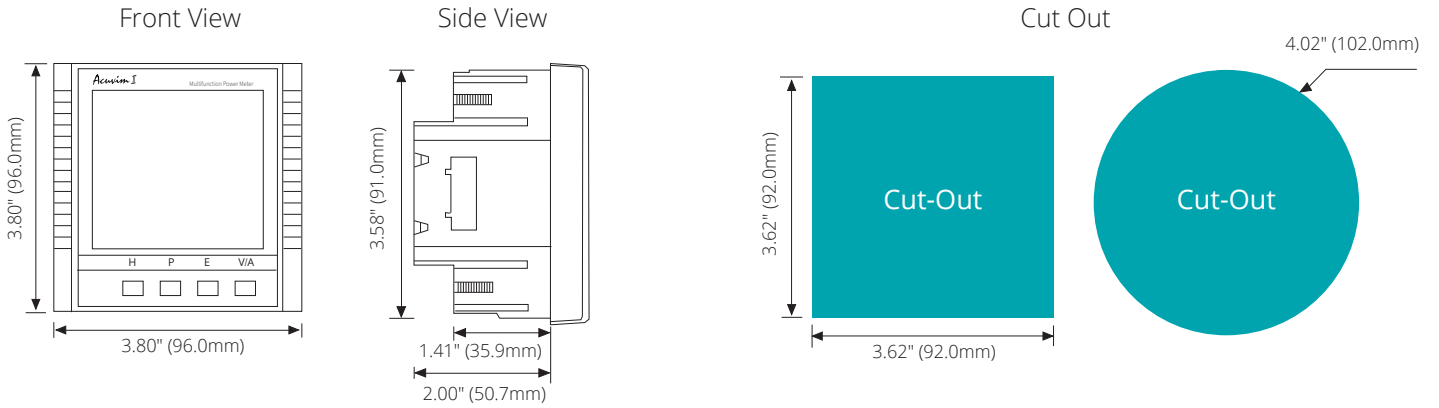

DIN Mount Meter Dimensions

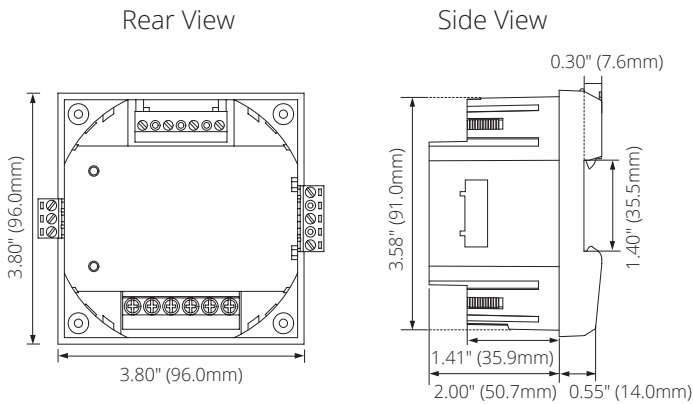

External Display Module Dimensions

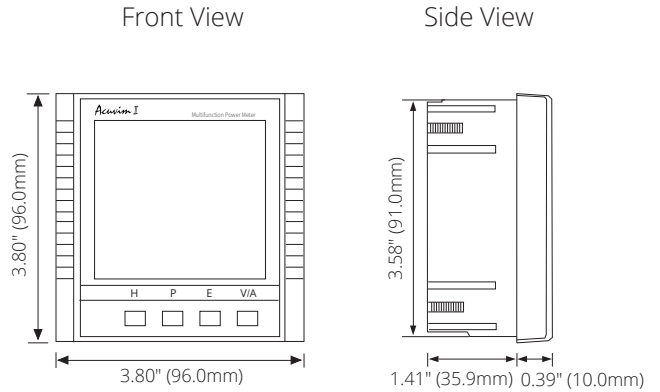

- Note:**
1. Display module is connected with a six foot 10 pin RJ45 cable, if you need a longer cable please specify that in the ordering statement.
 2. Display module opening size and Acuvim II body openings are exactly the same size.

I/O Module Dimensions

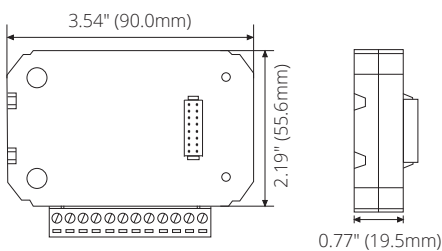

Communication Module Dimensions

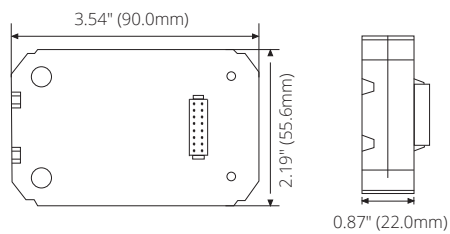

WIRING DIAGRAMS

Typical Wiring With 5A/1A CTs

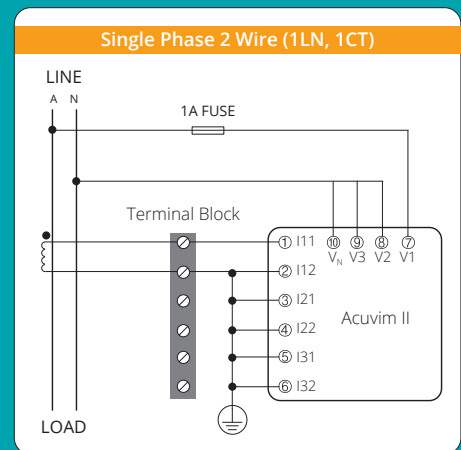
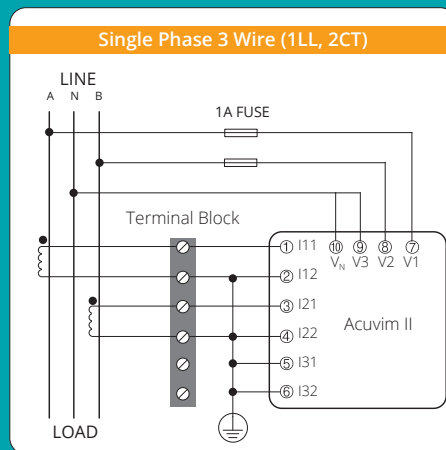
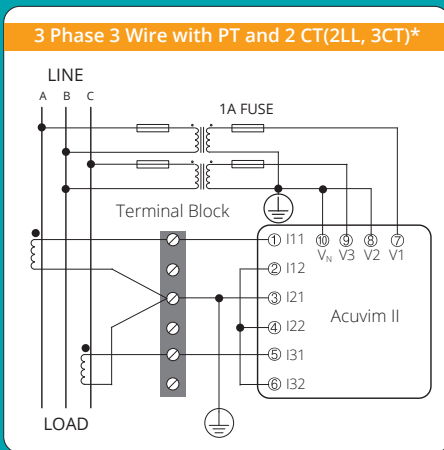
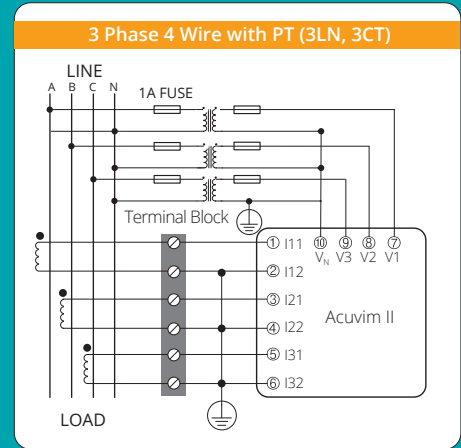
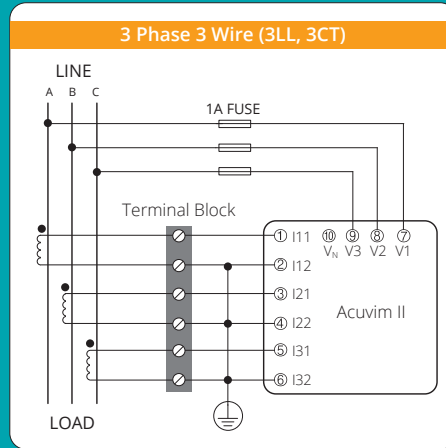
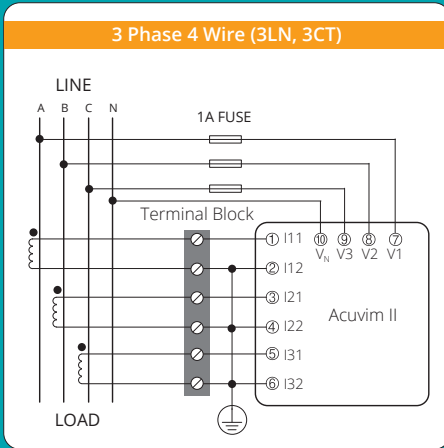

I/O Module Wiring

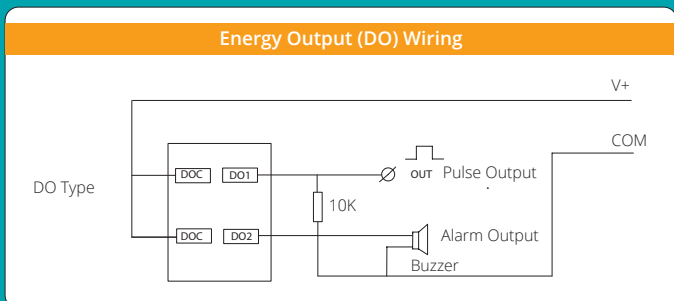
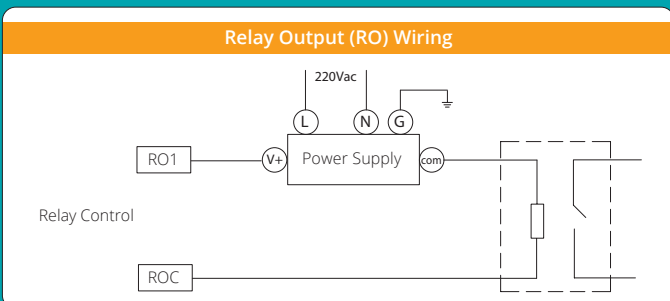
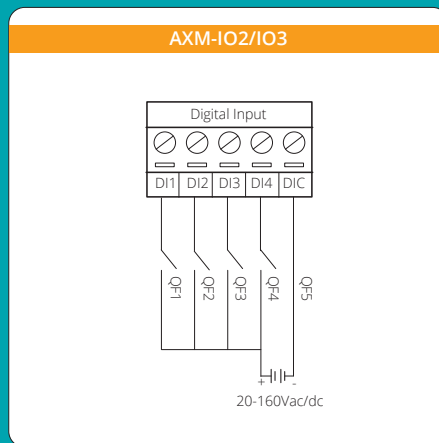
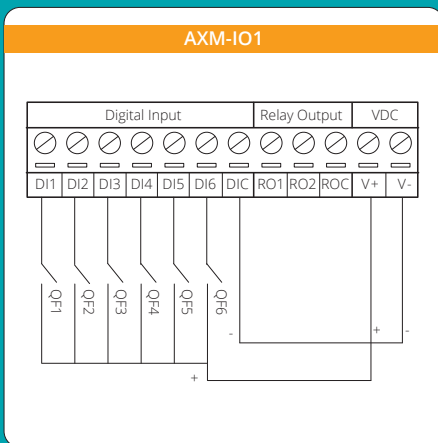

*Note: 2CT configuration is optional only in 3 Phase 3 Wire system.

WIRING DIAGRAMS

Typical Wiring RCT/mV/mA Current Input

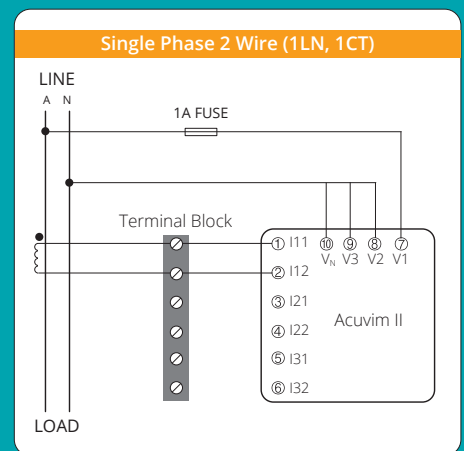
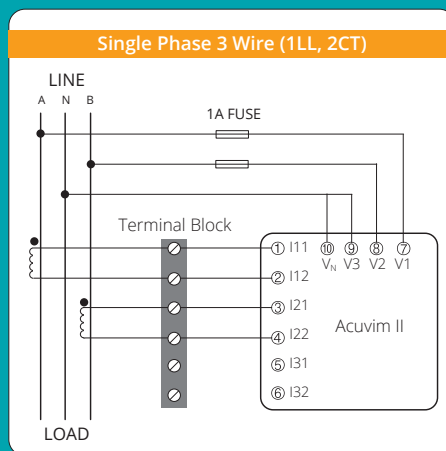
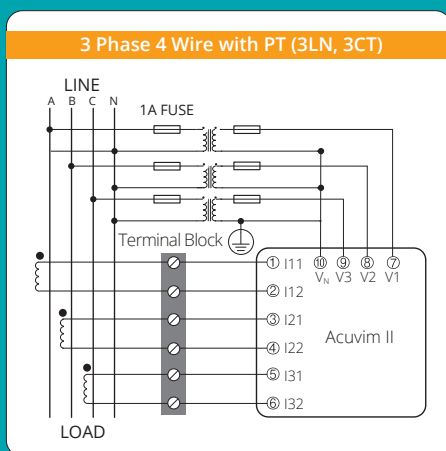
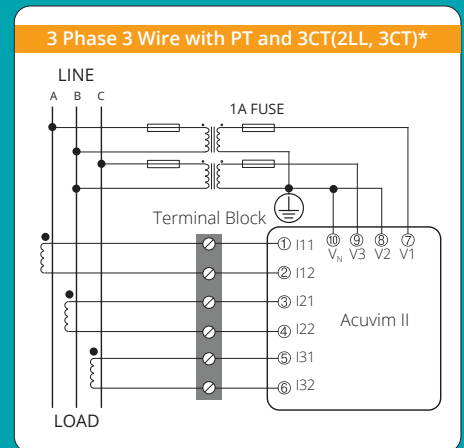
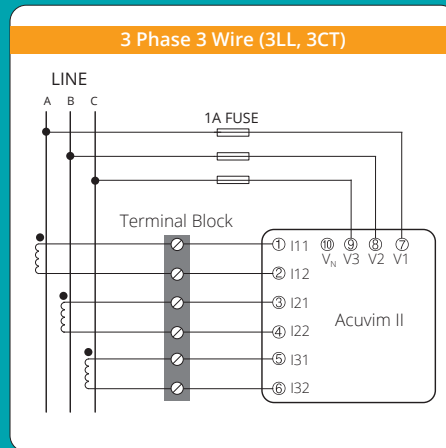
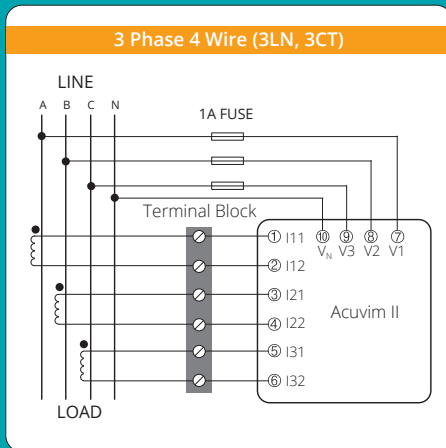

*Note: 2CT configuration is optional only in 3 Phase 3 Wire system.

ACCESSORIES

DIN Rail Adapter

The AXM-DIN Rail Adapter is the easy way to mount the Acuvim II Series energy meter on either horizontal or vertical DIN rail. The adapter quickly secures to the meter and is compatible with all AXM communication modules as well as I/O options.



Protective Display Cover

The Protective Display Cover is designed for Acuvim II Series energy meters and other 96mm by 96mm display panel meters. Crucial in harsh environments, it increases the IP environmental rating of a meter's display to IP66 or NEMA 4X.



USB RS485 Converter

This plug-and-play USB to Serial RS485 Converter is designed to provide a convenient, reliable USB connection to the Acuvim II Series power meters and other serial devices.



ORDERING INFORMATION

Meter Model	Mounting Option	Current Input	Power Supply
Acuvim II: Basic Model	D: LCD Display (Panel Mount Meter/Transducer)	5A: 5A/1A (Input Field Selectable)	P1: 100~415Vac, 50/60Hz, 100~300Vdc
Acuvim IIR: II + Data Logging	M: DIN-Rail Mount Transducer without Display (Optional Remote Display Available)	mA: 80mA/100mA/200mA (Input Field Selectable)	P2: 20~60Vdc
Acuvim IIE: IIR + Time of Use		RCT: AcuCT-Flex Input	
Acuvim IIW: IIR + Waveform Capture and PQ Event Logging		333: 333mV Input	

Ordering Example: Acuvim IIR-D-5A-P1

- Note:
1. Accuenergy suggests using USB-RS485 converter for configuration, and 3 CTs per three phase circuits.
 2. All fields must be completed to create a part number.
 3. Add "-S" after power supply for anti-tampering seal option.
 4. Contact Accuenergy for 400Hz frequency option; Acuvim IIW doesn't support this type.

Communication Module (Optional)	Protocols
AXM	WEB2-FOLC: IEC 61850, Modbus-TCP, HTTP/HTTPS Webserver, SMTP Email, SNMP, HTTP/HTTPS Push, FTP Post, sFTP Server, BACnet-IP, Datalogging, WiFi, Fiber Optics LC
	WEB2: IEC 61850, Modbus-TCP, HTTP/HTTPS Webserver, SMTP Email, SNMP, HTTP/HTTPS Push, FTP Post, sFTP Server, BACnet-IP, Datalogging, WiFi
	WEB-PUSH: Modbus-TCP, HTTP/HTTPS Webserver, SMTP Email, SNMP, HTTP/HTTPS Push, FTP Post, sFTP Server, Datalogging
	PROFI: PROFIBUS
	RS485: Modbus-RTU
	MESH-900: Wireless Radio (900MHz)
	MESH-868: Wireless Radio (868MHz)

Ordering Example: AXM-RS485

I/O Module (Optional)	Logic Module	Input/Output Type
AXM-IO1	1	
	2	
Ordering Example:	AXM-IO1-1	
AXM-IO2	1	A: 4~20mA
AXM-IO3	2	B: 0~20mA
		C: 1~5V
		D: 0~5V

Ordering Example: AXM-IO3-1B

- Note:
1. Refer to the Communication table and Digital/Analogue I/O table on page 6.
 2. A maximum of 3 modules may be attached to the meter. If a communication module is used (e.g. AXM-WEB2), it must be installed on the back FIRST before the other I/O modules are attached.
 3. No more than 2 of the same I/O modules may be attached to the meter (e.g. two AXM-IO2). The same two I/O modules must have a different logic number.
 4. If Acuvim IIW uses DI to trigger a waveform capture, the I/O module logic number must be Module 1.

Accessories (Optional)
REM-DS2: Remote Display (Only for Acuvim II DIN-Rail Mount "M" option)
AXM-DIN: DIN Rail Adapter
IP66/NEMA4X: Environmental Protection Cover
USB-RS485: USB-to-RS485 Converter
Ordering Example: AXM-DIN



Accuenergy (Canada) Inc.
Los Angeles - Toronto - Beijing - Pretoria
North America Toll Free: 1-877-721-8908
Web: www.accuenergy.com
Email: marketing@accuenergy.com

Revision Date: Mar 2022 Version: 1.0.2
Specs Subject To Change Without Notice.



ISO9001 Certified