

# AcuRev 2100

Multi-Circuit Submeter Datasheet

ACCUENERGY



## DESCRIPTION

The AcuRev 2100 Series is the next generation, multi-circuit submeter designed to measure in high-density applications using SnapOn CT technology. Ideal for multi-tenant billing applications, the AcuRev 2100 is engineered for revenue-grade monitoring of real-time energy consumption and high-precision power quality analysis in commercial, industrial, and residential facilities. Measurement Canada certification safeguards against unwanted tampering while support for multiple communication protocols promotes straightforward EMS integration.

## FEATURES

- + Revenue Grade: ANSI C12.20 0.5 class & IEC 62053-22 class 0.5s
- + Measure 18 single-phase or 6 polyphase circuits simultaneously
- + 8MB memory standard. WEB2 option adds 8GB of non-volatile memory for storing energy & power quality data
- + Combines easy remote meter access with industry-leading security features
- + Modbus-RTU ready. WEB2 option adds support for multiple industrial protocols & interfaces such as Modbus, BACnet, WiFi, and dual Ethernet
- + SnapOn CT technology reduces polarity errors as well as installation & maintenance times

## KEY FEATURES

### Complete Multi-Point Submetering Solution

- + Single-phase monitoring in high density applications
- + Analyze holistic energy usage to pinpoint cost-saving opportunities
- + Monitor per-circuit historical consumption trends
- + Energy: Active (kWh), reactive (kVARh) and apparent (kVAh)
- + Measure & verify utility bills with revenue-grade accuracy: ANSI C12.20 Class 0.5 & IEC62053-22 Class 0.5s
- + Directly measure voltage up to 690Vac L-L or 400Vac L-N
- + Real-time RMS Metering for each circuit
- + Power & power factor: Active (P), Reactive (Q), & Apparent (S)
- + Demand & peak demand: Total and per-circuit power and current demand with a 0-30 minute configurable window.

### Multi-Tariff Time of Use

- + TOU can be used according to different regional billing requirements. AcuRev 2100 series meters support up to 4 tariffs (sharp, peak, valley, normal), 14 schedules, 14 segments, weekends and 10-year holiday settings.

### Data Logging

- + Real-time energy, power quality, and I/O data can be stored in the onboard non-volatile memory. The WEB2 option extends the capabilities of the AcuRev 2100 and includes 8GB memory capable of saving years of metering data.

### Over/Under Limit Alarms

- + Ten limit alarms can be assigned to draw attention to various conditions. The alarm function is designed to effectively alert and protect systems by triggering notifications and automatically shutting down equipment.

### Input/Output (I/O)

- + AcuRev 2100 meters have 18 digital inputs (DI), 6 digital outputs (DO) and 2 relay outputs (RO) to easily integrate other metering data and control in a single unit.
- + 18 Digital Inputs: Dry contact inputs are designed to count pulses from devices with pulse output
- + 6 Digital Outputs: Used to send out pulses on energy data to an EMS
- + 2 Relay Outputs: Set up alarms & receive notifications when thresholds have been exceeded

### Power Quality Analysis

- + Critical to protecting sensitive electronic equipment, measure power quality parameters such as voltage and current THD, individual voltage and current harmonics up to the 31st order, voltage crest factor, current K factor, and voltage and current unbalance. All parameters are monitored real-time and logged in non-volatile memory.

### SnapOn CT Technology

- + Accuenergy's innovative CT technology allows any 80mA, 100mA, or 333mV current transformer to simply plug into the AcuRev 2100 submeter without any wiring configuration. This solution reduces common wiring mistakes and simplifies troubleshooting for a fast, convenient installation experience.

### Connect to Existing Networks

- + The AcuRev 2100 offers a simple, simultaneous connection to existing networks with built-in communication options including RS485. Dual Ethernet ports and WiFi are also available via the WEB2 communications option for advanced integration into any energy management system.

## APPLICATIONS

- + Commercial Complex/Mall
- + Apartment/Condominiums
- + Hospitals/Public Services
- + Hotels/Office Buildings
- + Tenant Submetering/Billing
- + Branch Circuit Monitoring
- + Energy Management Systems
- + Data Centers
- + LEED Projects



## SPECIFICATIONS

### Metering

PARAMETERS	ACCURACY	RESOLUTION	RANGE
Voltage	0.5%	0.1V	10~400V
Current	0.5%	0.001A	5mA~10,000A
Real Power	0.5%	0.1W	4000.0kW
Reactive Power	0.5%	0.1var	4000.0kvar
Apparent Power	0.5%	0.1VA	4000.0kVA
Power Factor	0.5%	0.001	-1.000~1.000
Frequency	0.2%	0.01Hz	45~65Hz
Active Energy	0.5%	0.1kWh	0~99999999.9kWh
Reactive Energy	0.5%	0.1kvarh	0~99999999.9kvarh
Apparent Energy	0.5%	0.1kVAh	0~99999999.9kVAh
Real Power Demand	0.5%	0.1W	4000.0kW
Reactive Power Demand	0.5%	0.1var	4000.0kvar
Apparent Power Demand	0.5%	0.1VA	4000.0kVA
Current Demand	0.5%	0.001A	5mA~10,000A
Unbalance	1%	0.01%	0~300%
Harmonics	1%	0.01%	0~100%
Meter Running Time		0.01hour	0~999999.9 hours
Temperature Drift	less than 100ppm/°C(0-50°C)		

### Input

#### CURRENT INPUTS (Each Channel)

Nominal Current Options	80mA, 100mA, 333mV, RCT Rogowski Coil
Accuracy	0.5% full scale

#### VOLTAGE INPUTS (Each Channel)

Nominal Full Scale	400Vac L-N, 690Vac L-L
Input Impedance	2MΩ/per phase
Metering Frequency	45Hz~65Hz
Burden	<0.2VA

### Communications

#### RS-485

1200-38400bps

#### PROTOCOLS

Modbus-RTU, Modbus-TCP/IP, BACnet-IP, SNMP,SNTP, SMTP, MQTT, HTTP/HTTPs Post, FTP, RSTP, IPv6

### Control Power

#### AC/DC CONTROL POWER

Operating Range	100~415Vac, 50~60Hz; 100-300Vdc
Power Consumption	5W

### Operating Environment

Operating Temperature	-25°C to 70°C
	-13°F to 158°F
Storage Temperature	-40°C to 85°C
	-40°F to 176°F
Relative Humidity	5% to 95% Non-Condensing

### I/O Options

#### DIGITAL INPUT

Input Type	Dry Node
Input Current (Max)	2mA
Pulse Frequency (Max)	100Hz, 50% Duty Cycle
SEO Resolution	2ms

#### DIGITAL OUTPUT (DO) (Photo-MOS)

Minimum Pulse Width	20-100ms, Programmable
Pulse Constant	1-60000imp/kWh, Programmable
Voltage Range	5-30Vdc
Load Current	5-50mA

#### RELAY OUTPUT (RO)

Load Voltage Range	250Vac, 30Vdc
Load Current	3A
Opening Time	10ms (Max)
Conduction Impedance	100mΩ (Max)
Isolation Voltage	4,000Vac
Mechanical Life	5,000,000 times

#### POWER SUPPLY FOR DI

Output Voltage	15Vdc
Rated Power	1W

### Standard Compliance & Certifications

Measurement Standard	IEC 62053-22 class 0.5s, ANSI C12.20 0.5 class
Environmental Standard	CE, RoHS
Safety Standard	UL 61010-1
Protocol Conformance	BTL Listed

## FUNCTION LIST

● Function; ◉ Option; Blank NA

	Function	Parameters	AcuRev 2110
Energy	Active Energy	Ep	●
	Reactive Energy	Eq	●
	Apparent Energy	Es	●
Time Of Use	4 Tariffs, 14 Schedules	TOU	●
Power Demand	Active Power Demand	Demand_P	●
	Reactive Power Demand	Demand_Q	●
	Apparent Power Demand	Demand_S	●
	Peak Power Demand	Demand_P_max	●
Current Demand	Current Demand	Total and each circuit	●
	Peak Current Demand	Total and each circuit	●
Real Time Metering	Phase Voltage	V1,V2,V3	●
	Line Voltage	V12,V23,V31	●
	Current	Total and each circuit	●
	Power	Total and each circuit	●
	Reactive Power	Total and each circuit	●
	Apparent Power	Total and each circuit	●
	Power Factor	Total and each circuit	●
Power Quality	Frequency	F	●
	Total Harmonic Distortion	THD*	●
	Individual Harmonics	2nd ~ 31st (Voltage and Current)*	●
	Current K Factor	KF	●
	Voltage Crest Factor	CF	●
	Voltage Unbalance	U_unbl	●
Time	Current Unbalance	I_unbl	●
	Real Time Clock (Year, Month, Date, Hour, Minute, Second)		●
Alarm	Over/Under Limit Alarming		●
Data Logging	8MB Memory		●
	8GB Memory		Web2 Option
Comm Ports	RS485 Modbus-RTU		●
	Ethernet Modbus-TCP, HTTP, BACnet-IP, SMTP, SNTP, SNMP		Web2 Option
	WiFi		Web2 Option
I/O Option	18 Digital Inputs with 15Vdc power supply		●
	6 Digital Outputs, Second Pulse, Demand Cycle		●
	2 Relay Outputs		●
Display	LCD		●

\*This function not available with the "RCT" current option

# DIMENSIONS

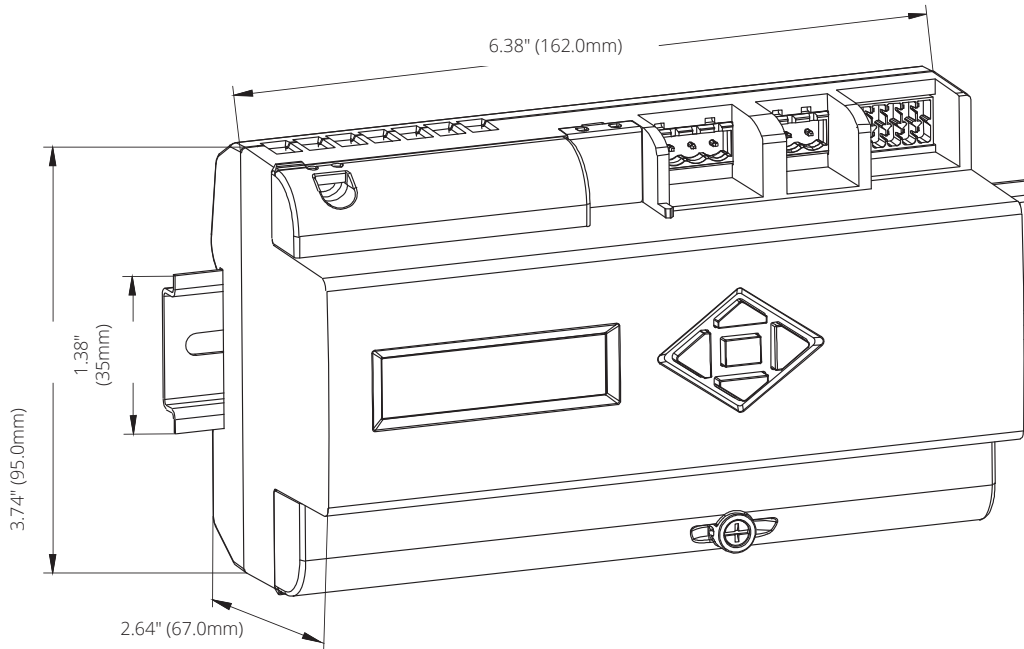

Front View

Side View

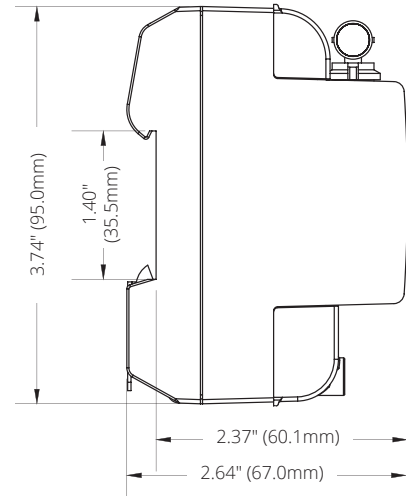
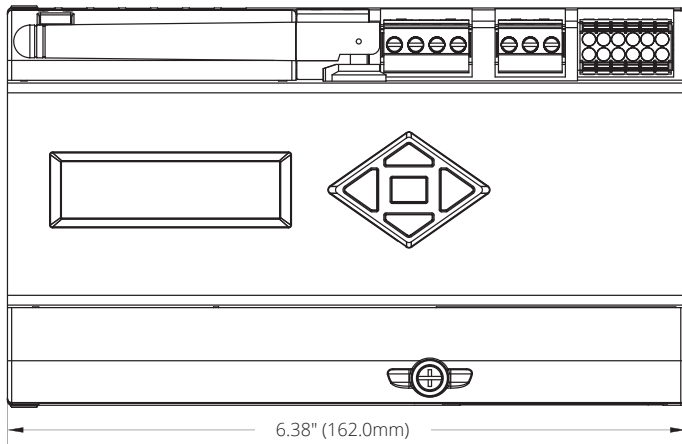

# WIRING DIAGRAMS

## Meter Terminals

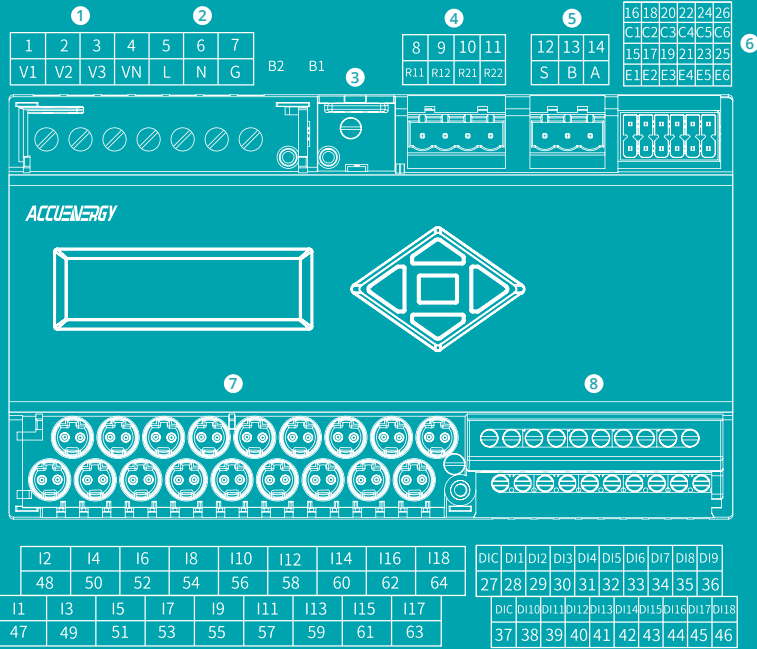

- 1 Voltage Input
- 2 Power Supply
- 3 Programming and Terminal Tamper-proof Seal
- 4 2 Relay Output
- 5 Serial RS485 Port
- 6 6 Digital Output
- 7 18 SnapOn CT Connectors
- 8 18 Digital Input

## Single Phase (1LN)

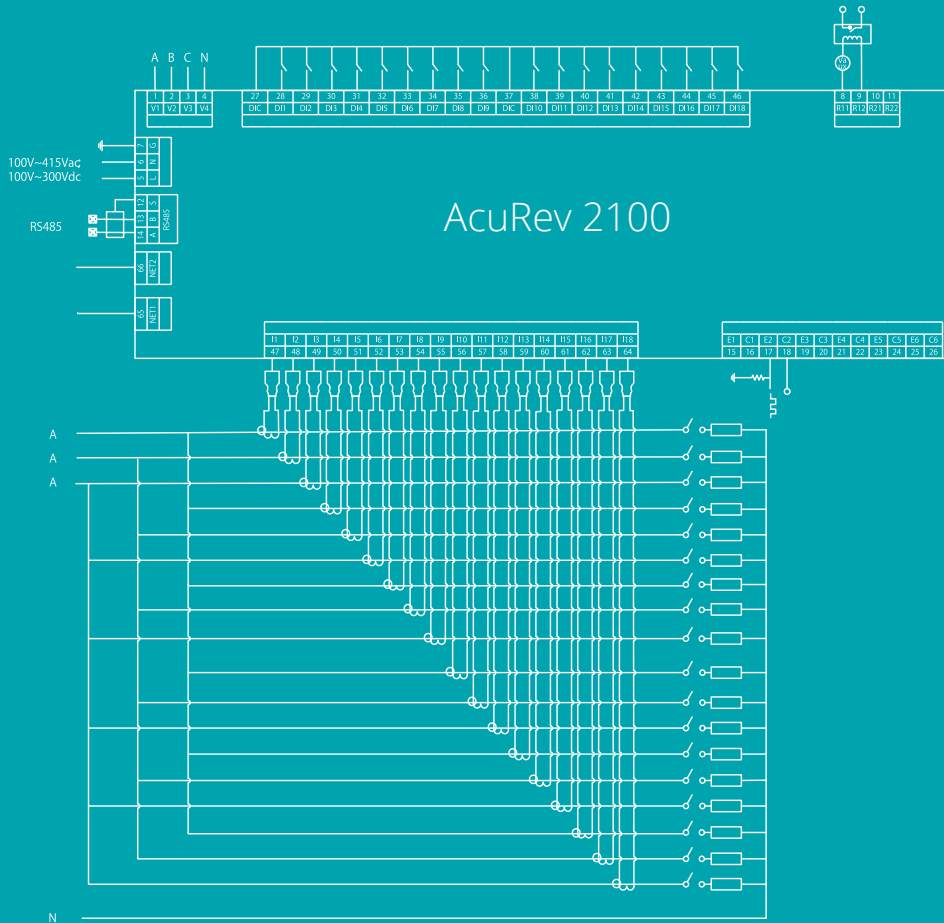



## ACCESSORIES

### Extra SnapOn Connectors

The AcuRev 2100 is supplied with 20 SnapOn CT connector heads that plug directly into the meter. Order extra connectors to outfit additional current transformers or keep a supply on-hand as replacements.



### IP67 Wall Mount Enclosure

This enclosure offers a secure wall mounting option for the AcuRev 2100 Series submeters and other DIN rail mountable devices. The enclosure is IP66/67 rated to ensure durability and is equipped with a steel mounting plate to facilitate flexible installation of DIN rail to suit a wide range of device mounting configurations.



### USB RS485 Converter

This professional-grade, plug-and-play USB to Serial RS485 Converter is compliant with both USB 1.1 and 2.0 standards and is designed to provide a convenient, reliable USB connection to the AcuRev 2100 Series multi-circuit submeters and other serial devices. It requires no external power supply and provides both surge and static electricity protection.



## ORDERING INFORMATION

+ Meter Model	- Current Input	- Communication Option
<b>AcuRev 2110:</b> Power Meter with Real-Time Data Logging and Advanced Power Quality	<b>mA:</b> 80mA and 100mA CT Input	<b>485:</b> Serial RS485
	<b>mV:</b> 333mV and Rogowski Coil Input	<b>WEB2:</b> Dual Ethernet, WiFi and Serial RS485
<b>Ordering Example:</b>	<b>AcuRev 2110-mV-WEB2</b>	

**Note:** 1. Accuenergy suggests using USB-RS485 converter for configuration, and 3 CTs per three phase circuits.  
2. All fields must be completed to create a part number.

+ Accessories (Optional)	
<b>USB-RS485:</b>	RS485 to USB converter for connecting meter with computer, maximum distance 1200 meters.
<b>ENC-12127P:</b>	NEMA 4X Enclosure
<b>SO-SP1:</b>	Replacement SnapOn Connectors (set of 20)
<b>Ordering Example:</b>	<b>ENC-12127P</b>

**Note:** *SnapON CT - SO-SP1*  
North America: White lead is positive. Black lead is negative.  
International: Red lead is positive. White lead is negative



**Accuenergy (Canada) Inc.**  
Los Angeles - Toronto - Beijing - Pretoria  
North America Toll Free: 1-877-721-8908  
Web: [www.accuenergy.com](http://www.accuenergy.com)  
Email: [marketing@accuenergy.com](mailto:marketing@accuenergy.com)

Revision Date: April 2022 Version: 1.0.1  
Specs Subject To Change Without Notice.



ISO9001 Certified